



A Design Study in Rapid Prototyping for Castings **Internal Interface Frame for LCD Digital Projector**

Design Study Outline

- [Introduction](#)
- [Design for Performance and Production](#)
 - Material and Process Selection*
 - Rapid Prototyping Process & Benefits*
 - Thin Wall Considerations*
 - Gating Design*
- [Final Mold Design](#)
- [Lessons Learned and Summary](#)



LCD Digital Business Projector LP130 from InFocus

[Start the Design Study !](#)



[Next](#)

Acknowledgment --

The metalcasting design studies are a joint effort of the American Foundry Society and the Steel Founders' Society of America. Project funding was provided by the American Metalcasting Consortium Project, which is sponsored by the Defense Supply Center Philadelphia and the Defense Logistics Agency, Ft. Belvoir, VA.



Copyright 2002 by the American Foundry Society
All rights reserved.
Address comments to: jss@afsinc.org
Last Modified: September, 2002 by STG





A Design Study in Rapid Prototyping for Castings

Interface Frame - Application

The LP130 LCD Digital Business Projector is a cutting edge portable LCD projector from the InFocus Corporation, Wilsonville, OR.



- The LP130 projector weights only 3 pounds with a 6.7 x 8.6 inch footprint.
- The design of the projector was driven by the requirement for low weight and size with high performance (XGA-1024 x 768, 1100 lumens, 400:1 contrast ration)

A critical factor in meeting the performance goals was to design internal structural components that minimize weight and maximize stiffness and strength



Copyright 2002 by the American Foundry Society. All rights reserved.
Address comments to: jss@afsinc.org
Last Modified: September, 2002 by STG



In cooperation with
[prototype casting, Inc](#)





A Design Study in Rapid Prototyping for Castings

Interface Frame -- Function

- One of the critical structural components in the projector is the internal interface frame.
- The frame couples and aligns the lamp assembly to the optical engine. The frame also fixtures two fans and several circuit boards.

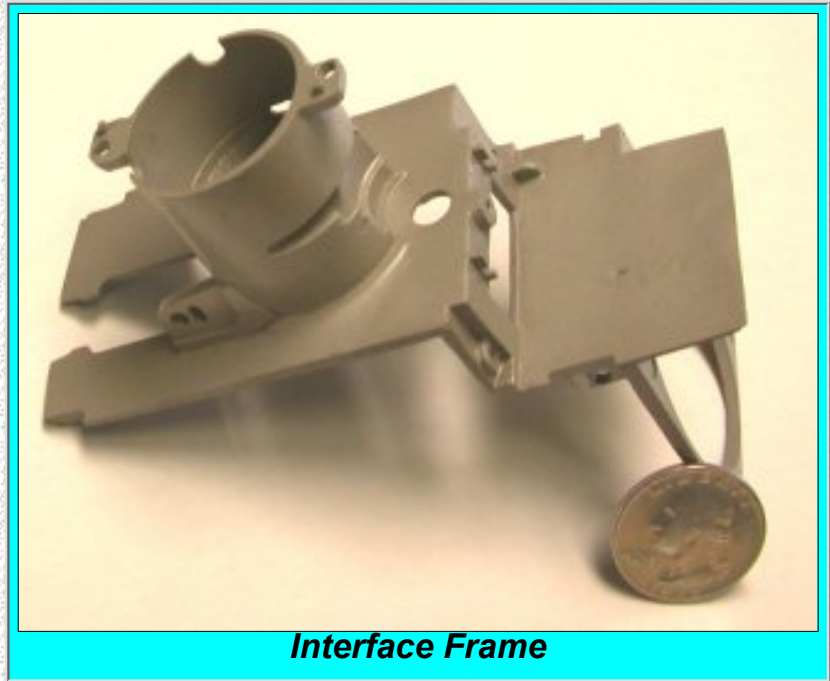

[Back](#) [Next](#)

3



[Return to AFS Home Page](#)

Copyright 2002 by the American Foundry Society. All rights reserved.
Address comments to: jss@afsinc.org
Last Modified: September, 2002 by STG



[Page 1](#)

In cooperation with
[prototype casting, Inc](#)





A Design Study in Rapid Prototyping for Castings

Interface Frame -- Description

The interface frame is a thinwall structural component, consisting of a two step flat bracket with a complex tube on the front face of the bracket.

- There are numerous mounting ears, alignment pins, cut-outs, and attachment points on the frame.

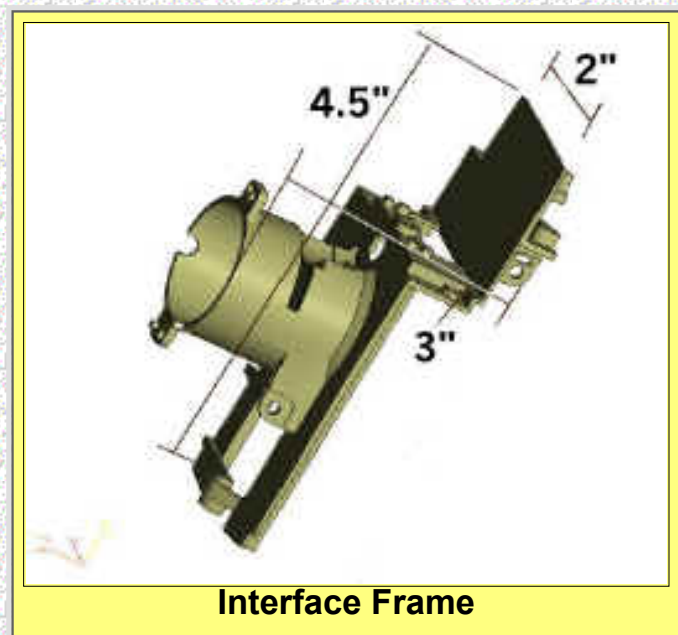

The overall dimensions are 4.5" x 3" x 2" with a nominal finished weight of 22 grams. The wall thicknesses are on the order of 0.05 in (1.2 mm)



[Back](#) [Next](#)

4



[Return to AFS](#)
[Home Page](#)

Copyright 2002 by the American Foundry Society All rights reserved.
Address comments to: jss@afsinc.org
Last Modified: September, 2002 by STG



[Page 1](#)

In cooperation with
[prototype](#)
[casting, Inc](#)





A Design Study in Rapid Prototyping for Castings

The Casting Design Issues

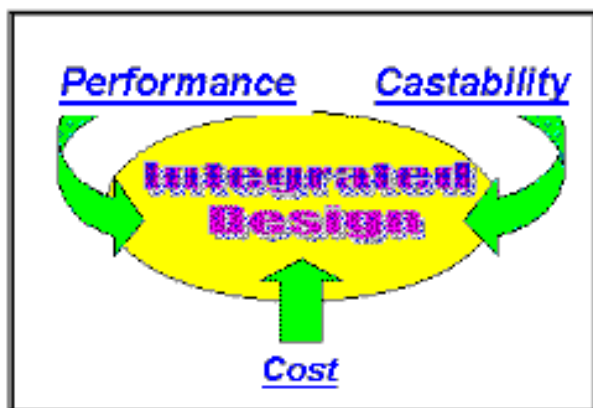

The Casting Design Approach -- The casting design engineers at InFocus teamed with the casting design team at Prototype Casting and focused on three design imperatives --

- *Design for Performance*
- *Design for Castability/Manufacturability*
- *Design for Cost*

Critical Casting Design Issues --The requirements for performance, castability/manufacturability, and cost are closely interconnected. Four casting design issues played a major role in meeting the three design imperatives

- Select a material to meet the performance requirements.
- Choose a production method that meets precision and cost targets.
- Use a rapid, efficient design/prototype methodology to reduce lead time.
- Design critical features for high yield production.



[Back](#) [Next](#)

6



[Return to AFS Home Page](#)

Copyright 2002 by the American Foundry Society. All rights reserved.
Address comments to: jss@afsinc.org
Last Modified: September, 2002 by STG



[Page 1](#)

In cooperation with
[prototype casting, Inc](#)





A Design Study in Rapid Prototyping for Castings

Material Selection

A fundamental design decision is the selection of a specific material that best meets the desired performance and production requirements.

For the interface frame, the ideal material should have --

- **Minimum weight**
- **High structural stiffness and low thermal expansion**
- **High thermal conductivity and high heat tolerance**
- **Ability to achieve complex thin wall shape and precision features.**
- **Near-net shape, low cost, high volume production.**

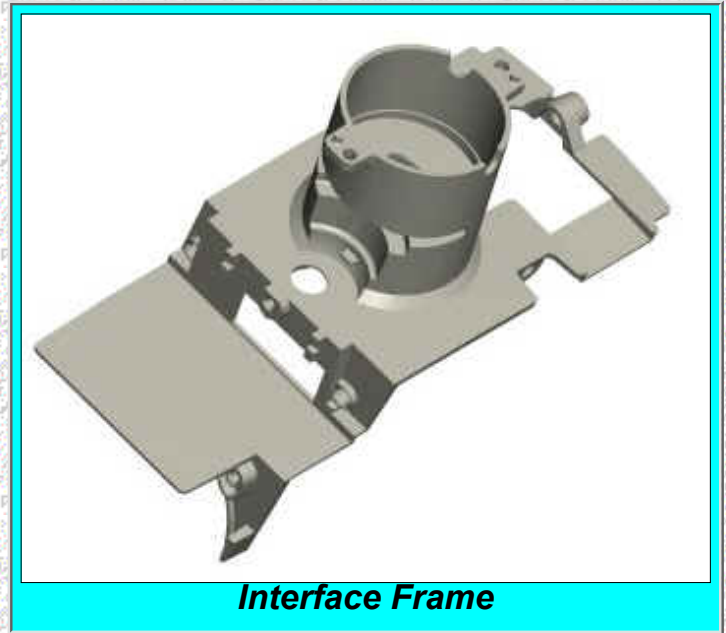

[Back](#) [Next](#)



Copyright 2002 by the American Foundry Society. All rights reserved.

Address comments to: jss@afsinc.org

Last Modified: September, 2002 by STG

[Return to AFS Home Page](#)



[Page 1](#)

In cooperation with
prototype casting, Inc





A Design Study in Rapid Prototyping for Castings

Material Options

Three low density materials were considered for the interface frame:

- High Performance, High Temperature Polymer -- Polyimide
- Structural Magnesium Alloy - AZ91D
- Structural Aluminum Alloy - A356

	Polyimide	Magnesium	Aluminum
<i>Density (g/cc)</i>	1.43	1.81	2.68
<i>Elastic Modulus (MSI)</i>	0.45	6.5	10.5
<i>Thermal Conductivity (W/mK)</i>	0.25	72	150
<i>Thermal Expansion (10⁻⁶/K)</i>	57	26	22
<i>Deflection/Solidus Temperature (C)</i>	360 (D)	470 (S)	555 (S)
<i>Ultimate Tensile Strength (ksf)</i>	12.5	33	38

Which material (polyimide, magnesium, or aluminum) best meets the requirements for low density, high modulus, high thermal conductivity, low thermal expansion, high temperature stability, and high tensile strength?



[Back](#)

8



[Return to AFS Home Page](#)

Copyright 2002 by the American Foundry Society All rights reserved.
Address comments to: jss@afsinc.org
Last Modified: September, 2002 by STG



[Page 1](#)

In cooperation with
[prototype casting, Inc](#)





A Design Study in Rapid Prototyping for Castings

Polyimide

- The polyimide resin has the lowest density (1.43 g/cc) compared to the two metals.
- But it does not match the stiffness/modulus, thermal conductivity, temperature capability, or strength of either magnesium or aluminum.
- In addition, the polyimide has significantly higher thermal expansion, compared to the metals.

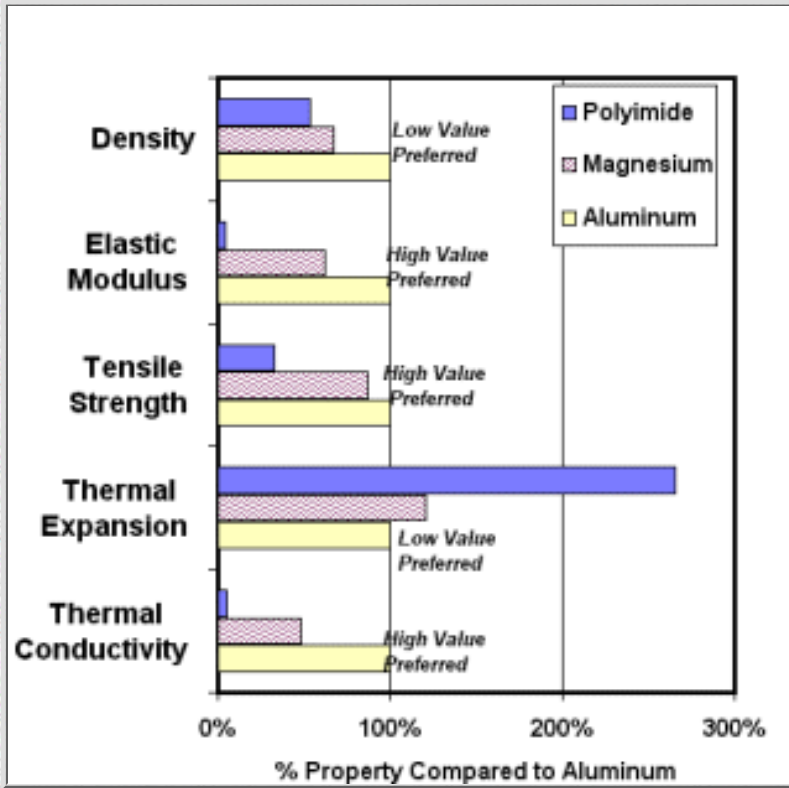

The polyimide is not the material of choice
[Go back and select another material.](#)



[Back](#)

9



[Return to AFS Home Page](#)

Copyright 2002 by the American Foundry Society. All rights reserved.
 Address comments to: jss@afsinc.org
 Last Modified: September, 2002 by STG



[Page 1](#)

In cooperation with
[prototype casting, Inc](#)





A Design Study in Rapid Prototyping for Castings

Magnesium

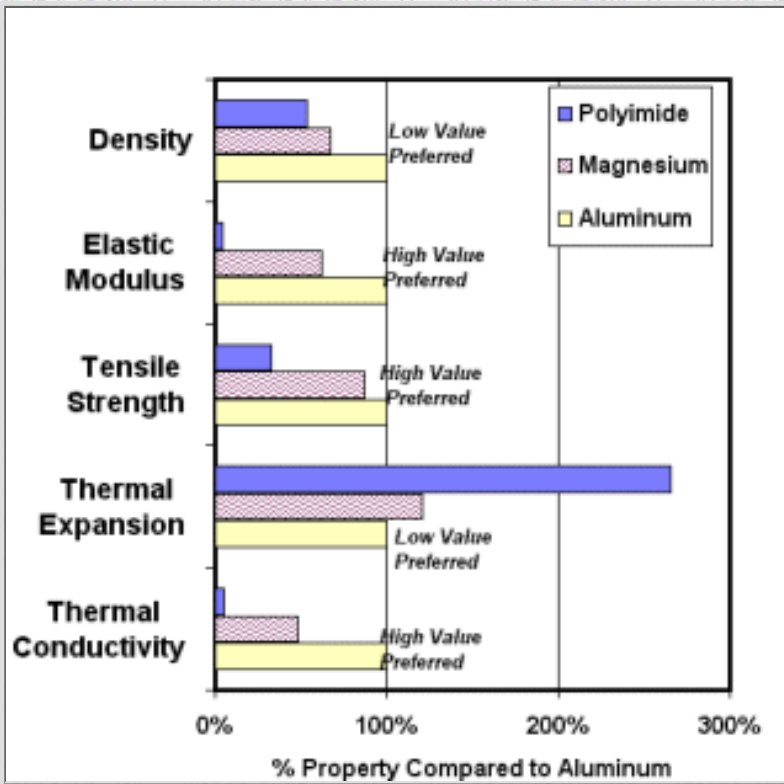

- The magnesium alloy has much higher values for modulus, thermal conductivity, tensile strength, and thermal stability, as compared to the polyimide polymer.
- In addition, the magnesium has a 33% weight savings over the aluminum, even though the aluminum has a moderate benefit in mechanical and thermal properties.
- Given the imperative to save weight, the magnesium is the material of choice

The magnesium is the best choice
Go the next design issue!



[Back](#) [Next](#)

10



[Return to AFS](#)
[Home Page](#)

Copyright 2002 by the American Foundry Society. All rights reserved.
 Address comments to: jss@afsinc.org
 Last Modified: September, 2002 by STG



Page 1

In cooperation with
[prototype casting, Inc](#)





A Design Study in Rapid Prototyping for Castings

Aluminum

- The aluminum, like the magnesium, has a much higher modulus, thermal conductivity, tensile strength, and thermal stability, as compared to the polyimide polymer.
- But the aluminum has a much higher density than the magnesium, without a comparable benefit in strength of thermal expansion.
- Given the imperative to save weight, the aluminum is not the material of choice.

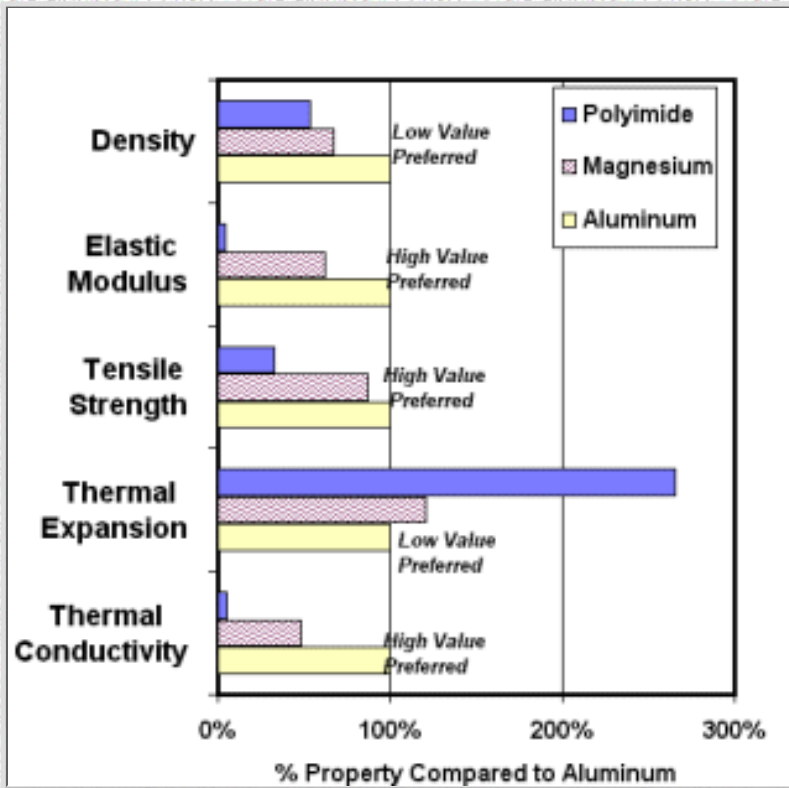

The aluminum is not the material of choice
[Go back and select another material.](#)



[Back](#)

11



[Return to AFS Home Page](#)

Copyright 2002 by the American Foundry Society. All rights reserved.
 Address comments to: jss@afsinc.org
 Last Modified: September, 2002 by STG



[Page 1](#)

In cooperation with
[prototype casting, Inc](#)





A Design Study in Rapid Prototyping for Castings

Interface Frame - Production Options



- The production requirement for the projector is 60,000 to 80,000 units per year.
- The design engineers at InFocus had three options for manufacturing the interface frame in magnesium --

Production Method

Characteristics

Machining from Metal Stock

Too expensive and time consuming for high volume production

Multi-part sheet metal assembly

Tolerance/alignment limitations and high assembly costs

Metal Casting

Tight tolerance capability and low cost, high volume production

It was obvious that a one piece precision casting would provide the best performance at a market acceptable cost for this high volume precision component



[Back](#) [Next](#)



[Return to AFS Home Page](#)

Copyright 2002 by the American Foundry Society. All rights reserved.
Address comments to: jss@afsinc.org
Last Modified: September, 2002 by STG



Page 1

In cooperation with
[prototype casting, Inc](#)





The Design Approach - Rapid Prototyping

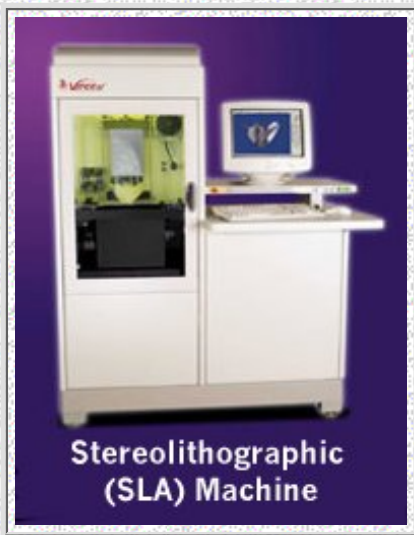

The upfront challenge for the design engineers was how to rapidly and cost-effectively design and verify an optimized component configuration.

- In the past, the design effort would have required iterative diecasting prototypes based on machined dies, requiring long lead times and high cost.

- Design engineers don't have the luxury of long lead times in today's competitive, short cycle time market. They need a verified casting design ASAP.
- InFocus went to the design team of Prototype Casting, Denver, CO to work with their rapid prototyping capability to develop and test a cost-effective design for cast components.



[Back](#) [Next](#)

13



[Return to AFS Home Page](#)

Copyright 2002 by the American Foundry Society. All rights reserved.
Address comments to: jss@afsinc.org
Last Modified: September, 2002 by STG



[Page 1](#)

In cooperation with
[prototype casting, Inc](#)





A Design Study in Rapid Prototyping for Castings

Rapid Prototyping -- The Process

Prototype Casting uses a 5-step process to produce high quality magnesium, aluminum and zinc prototypes with a 5-10 day turn-around time.

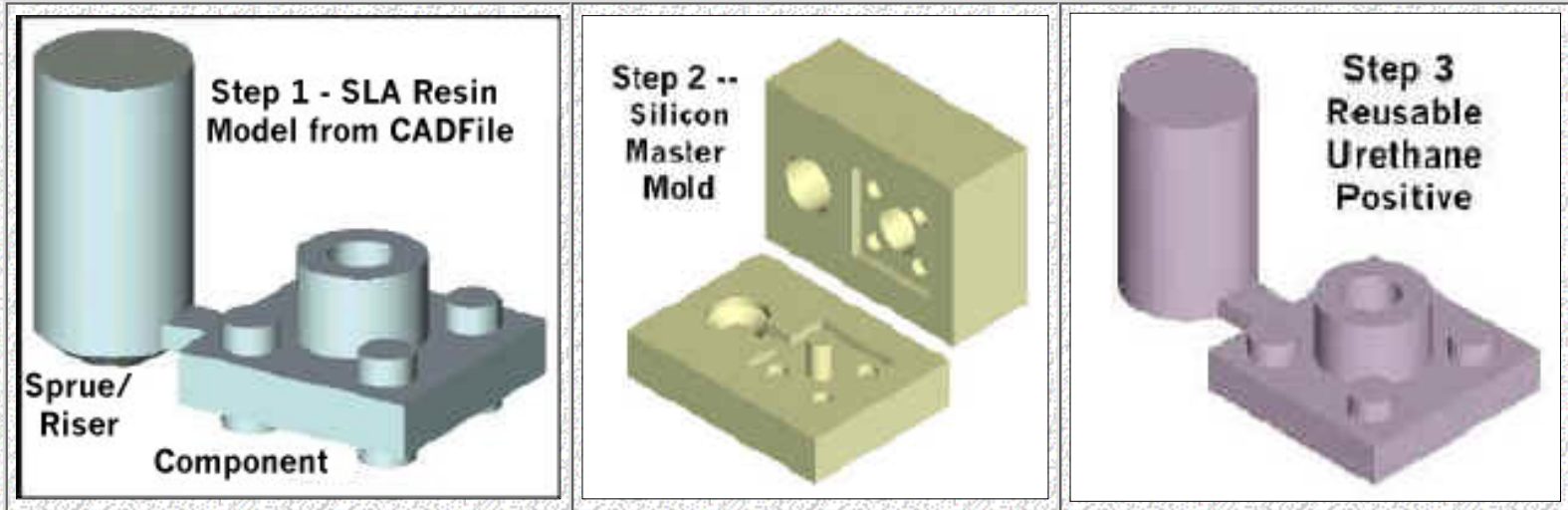

Steps 4 and 5 on the next page



[Back](#) [Next](#)



[Return to AFS Home Page](#)

Copyright 2002 by the American Foundry Society. All rights reserved.
Address comments to: jss@afsinc.org
Last Modified: September, 2002 by STG



[Page 1](#)

In cooperation with
[prototype casting, Inc](#)





A Design Study in Rapid Prototyping for Castings

Rapid Prototyping -- The Process

The metal casting is produced by pouring the molten metal into the disposable plaster mold to get a near-net-shape casting.

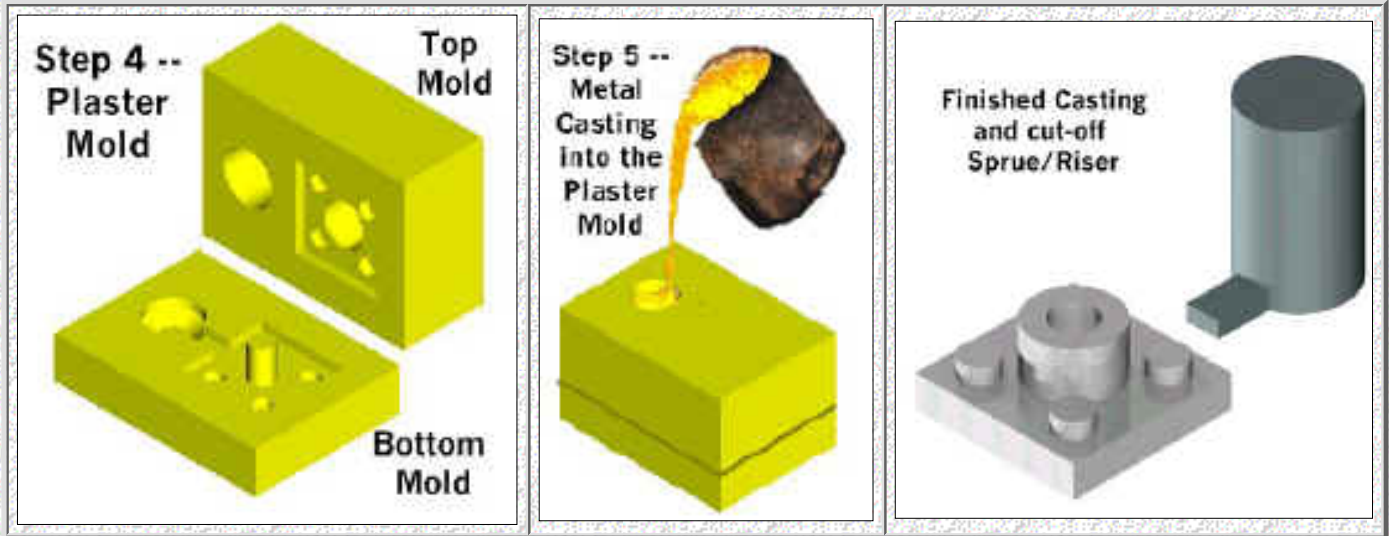

Copyright 2002 by the American Foundry Society. All rights reserved.
Address comments to: jss@afsinc.org
Last Modified: September, 2002 by STG



In cooperation with
[prototype casting, Inc](#)





A Design Study in Rapid Prototyping for Castings

SLA Resin Model



Rapid Prototyping -- Benefits & Capabilities

Prototype Casting uses rapid prototyping and casting technology to turn complex CAD designs into metal castings.

- The customer receives a finished metal casting, suitable for form, fit, and function tests.
 - Design iterations can be done in a 5-7 day cycle time.
 - Performance and manufacturing design issues can be quickly identified and optimized, based on the metal prototypes.
 - Casting capabilities include thin walls, intricate geometry with multiple slides or cores, zero draft and complex parting lines.
- Wall thicknesses of 0.050" are common; 0.025" is possible depending on feature geometry.
 -- Tolerances of +/- 0.005" for the 1st inch; +/- 0.002" for each inch thereafter



[Back](#) [Next](#)



[Return to AFS Home Page](#)

Copyright 2002 by the American Foundry Society. All rights reserved.
 Address comments to: jss@afsinc.org
 Last Modified: September, 2002 by STG



[Page 1](#)

In cooperation with
[prototype casting, Inc](#)





Design Issues -- Thin Wall Considerations

- The casting design engineer has to ensure that the molten metal will flow smoothly and rapidly into all sections of the die to produce a flaw free component.

-- Molten magnesium cools quickly and can solidify prematurely in thin, very narrow side wall sections, blocking metal flow into the mold.

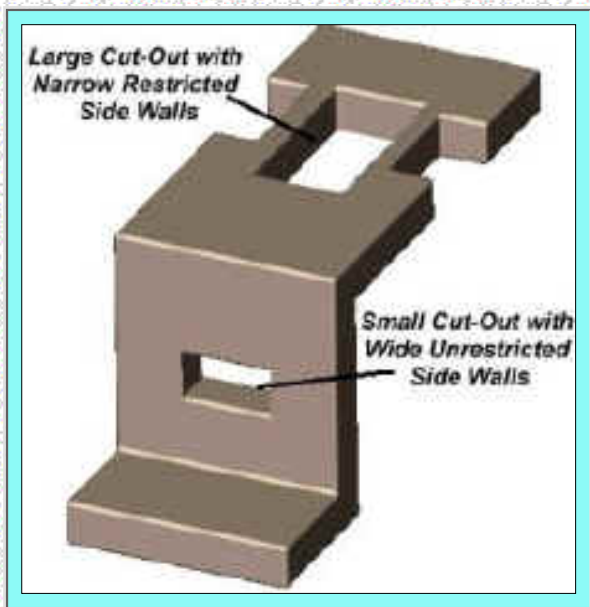

- For thin wall castings, it is important to decide what features (cut-outs, holes, slots) would severely restrict fluid flow in the mold.
- Those features should be machined, rather than formed by cores in the mold.



[Back](#) [Next](#)

17



[Return to AFS Home Page](#)

Copyright 2002 by the American Foundry Society. All rights reserved.
Address comments to: jss@afsinc.org
Last Modified: September, 2002 by STG



[Page 1](#)

In cooperation with
[prototype casting, Inc](#)





A Design Study in Rapid Prototyping for Castings

Thin Wall Considerations

The drawing of the finished frame to the right shows two features which may restrict metal flow if they are produced in the casting, rather than by rough machining.

[Feature A -- Top Plate Cut-Out](#)

[Feature B -- Side Step Cut-Out](#)

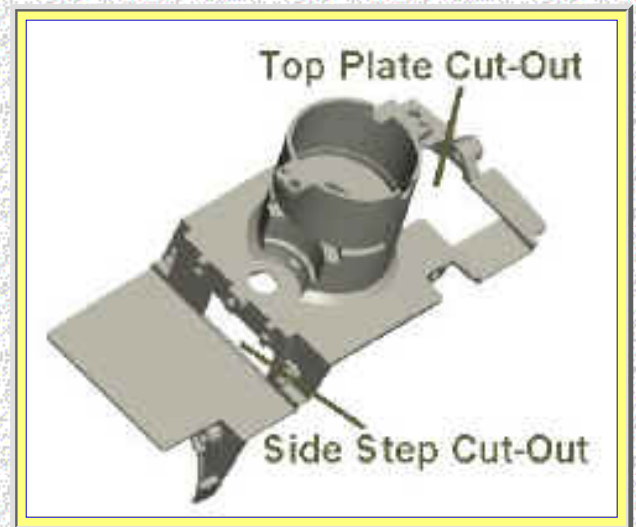

**Choose the Feature
([A-Top Plate Cut-Out](#) or [B- Side Step Cut-Out](#))
which should be considered for rough machining,
rather than net-shape casting with cores.**



[Back](#)

18



[Return to AFS
Home Page](#)

Copyright 2002 by the American Foundry Society. All rights reserved.

Address comments to: jss@afsinc.org

Last Modified: September, 2002 by STG



[Page 1](#)

In cooperation with
[prototype
casting, Inc](#)





A Design Study in Rapid Prototyping for Castings

Feature A - Top-Plate Cut-Out

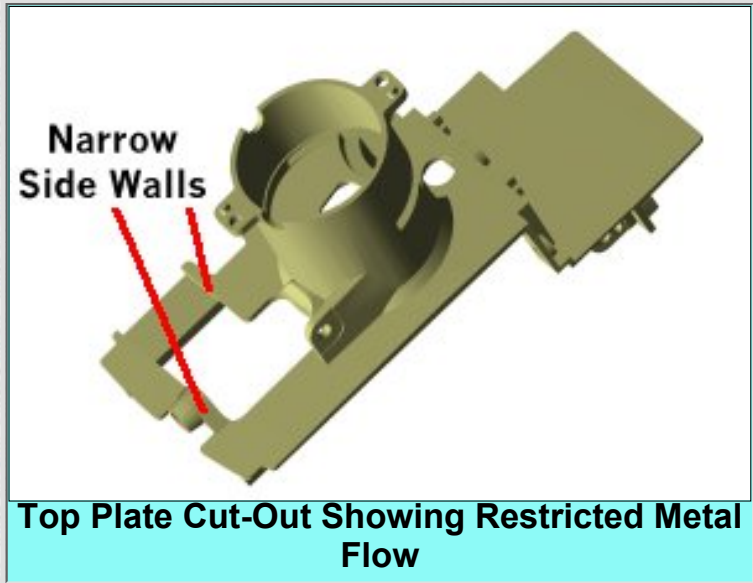

- In Feature A, the top plate cut-out is relatively large and long, compared to the section size.
- If the cut-out is produced in the casting, metal flow in the side and far edges of the top plate could be restricted, limiting flow into the far edge.

Feature A **does** need to be rough machined in after casting.
[Go on to the next design issue](#)



19



[Return to AFS Home Page](#)

Copyright 2002 by the American Foundry Society. All rights reserved.
 Address comments to: jss@afsinc.org
 Last Modified: September, 2002 by STG



[Page 1](#)

In cooperation with
[prototype casting, Inc](#)





A Design Study in Rapid Prototyping for Castings

Feature B - Side Step Cut-Out

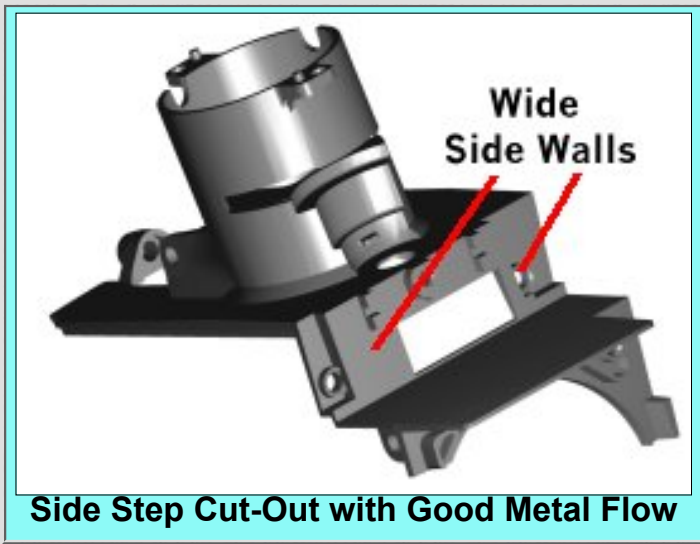

- In Feature B, the side-step cut-out is a small enough feature that metal flow in the side walls will be smooth and unrestricted into the lower step.
- The cut out can also be easily produced with a feature on the bottom mold, without using an extra core, which would increase cost and mold complexity.

Feature B is **best** produced in the casting, rather than by machining.
[Go back and choose another feature.](#)



[Back](#)

20



[Return to AFS Home Page](#)

Copyright 2002 by the American Foundry Society. All rights reserved.
 Address comments to: jss@afsinc.org
 Last Modified: September, 2002 by STG



[Page 1](#)

In cooperation with
[prototype casting, Inc](#)





A Design Study in Rapid Prototyping for Castings

Gating System Design

The gating system serves as the flow path for molten metal from the down sprue into the mold cavity.

Proper design of the gating system is critical to provide for uniform, controlled metal flow.

- Non-uniform, long path, and/or slow metal flow may produce unfilled sections or solidification shrinkage in the casting.
- Excessively rapid metal flow or metal splashing will cause turbulence and produce oxidation of the metal.
- In-gates should be --
 - large enough for rapid, but smooth, metal flow into the mold.
 - shaped to avoid sharp transitions and turbulence at the entry point.

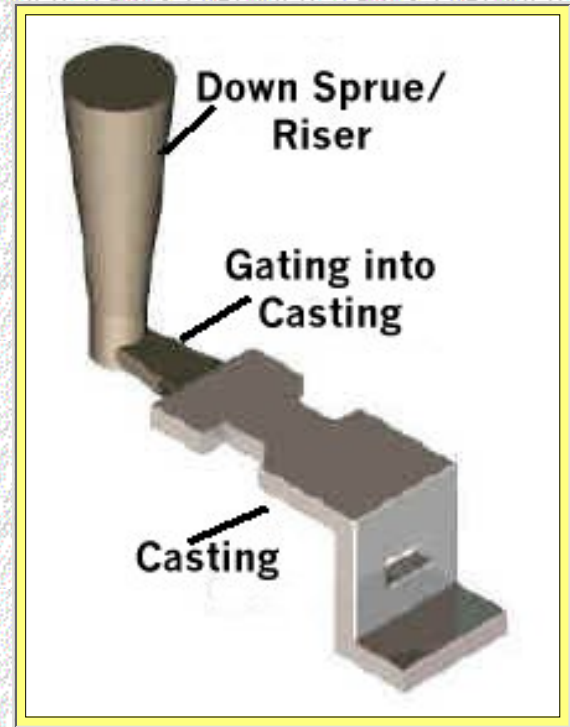

[Back](#) [Next](#)

21



[Return to AFS Home Page](#)

Copyright 2002 by the American Foundry Society. All rights reserved.
Address comments to: jss@afsinc.org
Last Modified: September, 2002 by STG



[Page 1](#)

In cooperation with
[prototype casting, Inc](#)





A Design Study in Rapid Prototyping for Castings

Gating Design

The interface frame will be gated directly into the center cylinder of the frame.

The drawing shows two designs for the in-gate on the frame

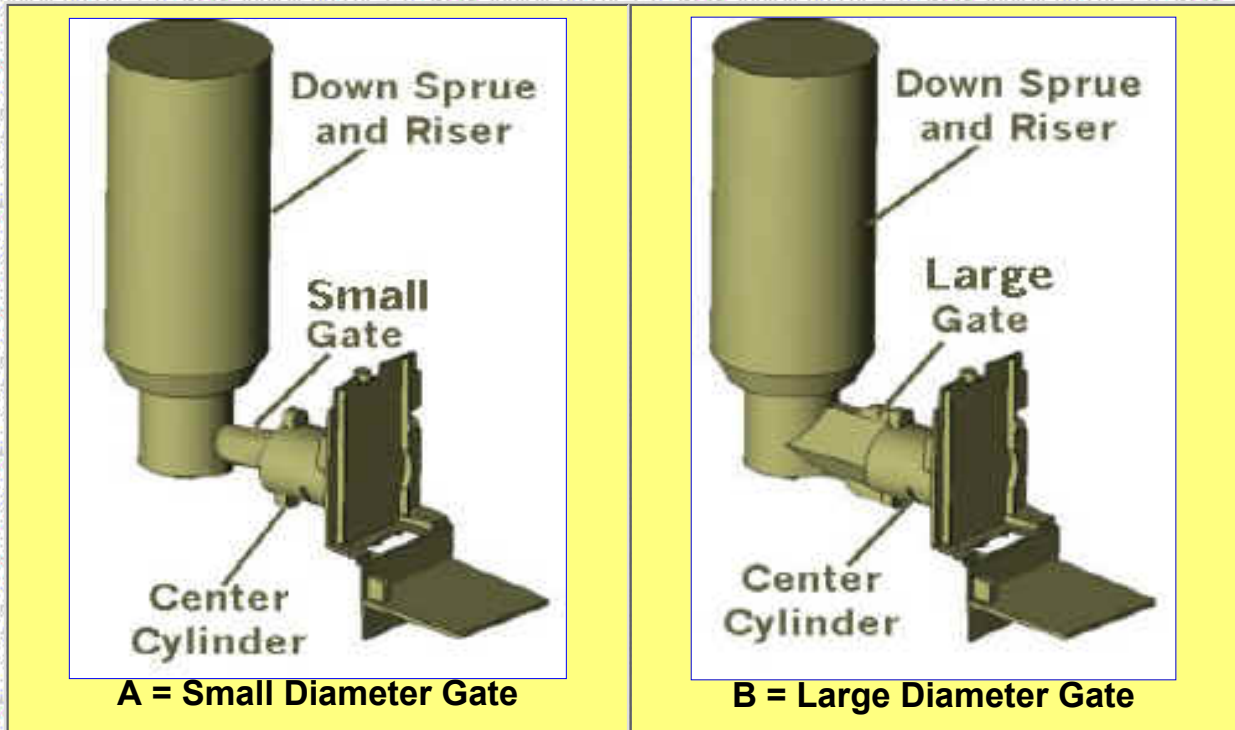

Which Gating System Design (Design A or Design B) will provide the more rapid, less turbulent flow into the mold cavity?



[Back](#)



[Return to AFS Home Page](#)

Copyright 2002 by the American Foundry Society. All rights reserved.
Address comments to: jss@afsinc.org
Last Modified: September, 2002 by STG



Page 1

In cooperation with
[prototype casting, Inc](#)





A Design Study in Rapid Prototyping for Castings

Design A - Small Diameter Gate

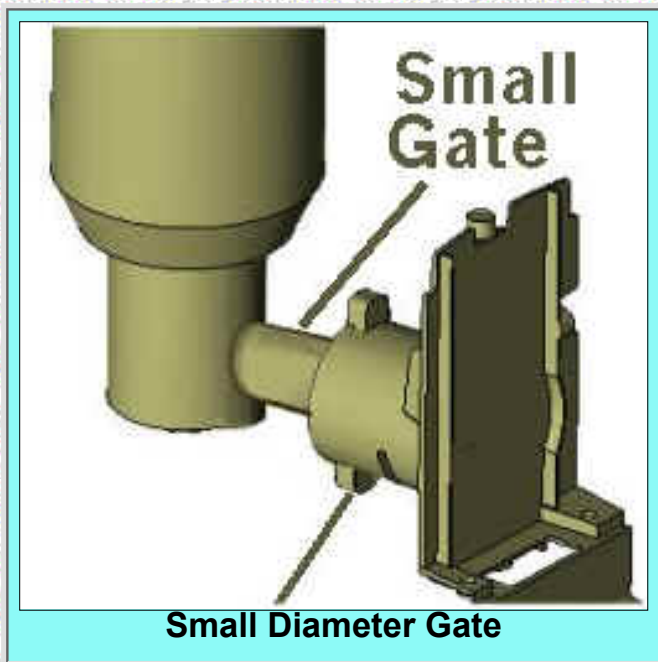

- In this design, the gate into the interface frame is a small diameter tube feeding directly into the large diameter center cylinder.
- The small diameter gate will slow down the metal flow and prevent rapid filling of the mold.
- In addition, the sharp transition from the small diameter gate to the large diameter bore will produce significant turbulence and splashing.

The small diameter gate is **NOT** a good design
[Go back and choose another design approach](#)



[Back](#)

23



[Return to AFS Home Page](#)

Copyright 2002 by the American Foundry Society All rights reserved.

Address comments to: jss@afsinc.org

Last Modified: September, 2002 by STG



[Page 1](#)

In cooperation with
[prototype casting, Inc](#)





A Design Study in Rapid Prototyping for Castings

Design B - Large Diameter Gate

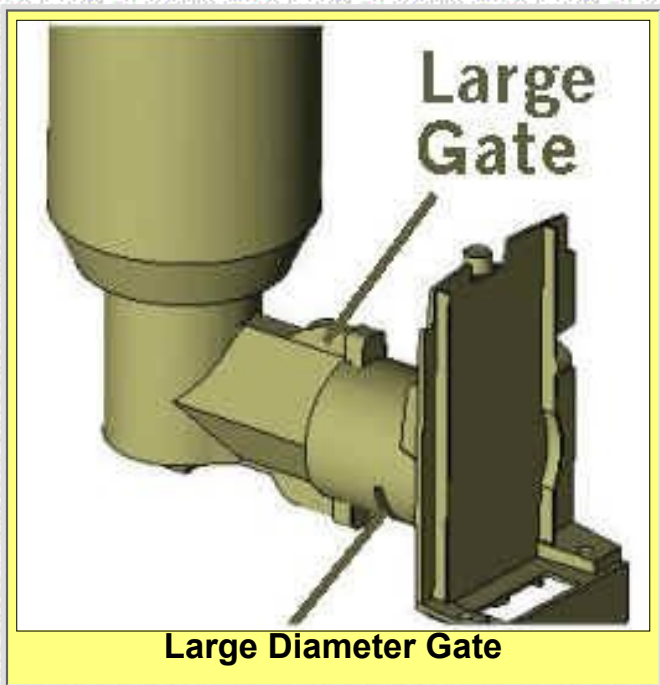

- In this design, the gate into the interface frame is a large diameter tube feeding directly into the large diameter center cylinder.
- The large diameter gate will produce rapid, controlled filling of the mold.
- The diamond shape cross section and the smooth transition into the center cylinder on the frame will give laminar flow into the smaller features on the perimeter of the center cylinder, reducing turbulence.

The large diameter gate **IS** a good design
[Go on to the next design issue.](#)



[Back](#) [Next](#)

24



[Return to AFS](#)
[Home Page](#)

Copyright 2002 by the American Foundry Society. All rights reserved.
 Address comments to: jss@afsinc.org
 Last Modified: September, 2002 by STG



[Page 1](#)

In cooperation with
[prototype casting, Inc](#)





Casting Mold Design Optimization

- The casting design engineer always optimizes his casting design, balancing benefits versus costs and considering how complex features can be produced in the casting.
- In the perfect situation, the casting can be produced in net-shape, with every feature produced in the mold and no finish machining required.
- In the real world, increased mold complexity and cost have to be compared against the costs of rough and finish machining, considering the required production volume.

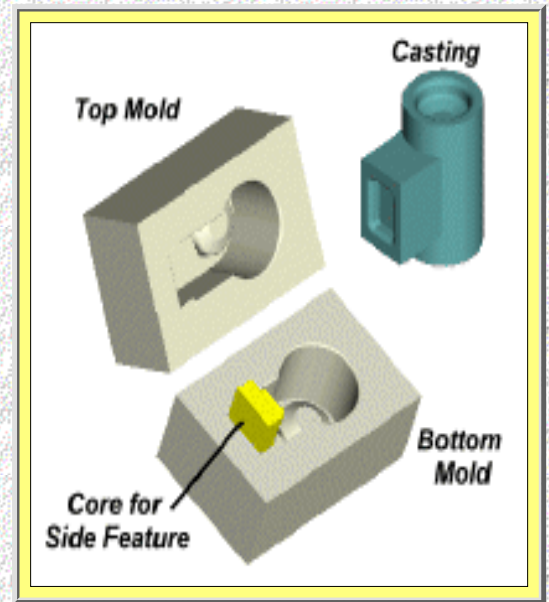

Special features in castings are often produced by additional removable mold components, commonly called "cores."



[Back](#) [Next](#)



Copyright 2002 by the American Foundry Society. All rights reserved.
 Address comments to: jss@afsinc.org
 Last Modified: September, 2002 by STG

[Return to AFS Home Page](#)



[Page 1](#)

In cooperation with
[prototype casting, Inc](#)





Final Mold Design

- Prototype Casting produced the interface frame in magnesium using a three part mold design with a top mold, a bottom mold, and one core.
- Risers and gating are carefully engineered to optimize flow and fill into the thin walls of the casting.
 - This produces a casting free of misruns, shrinkage voids, porosity and cold tears.

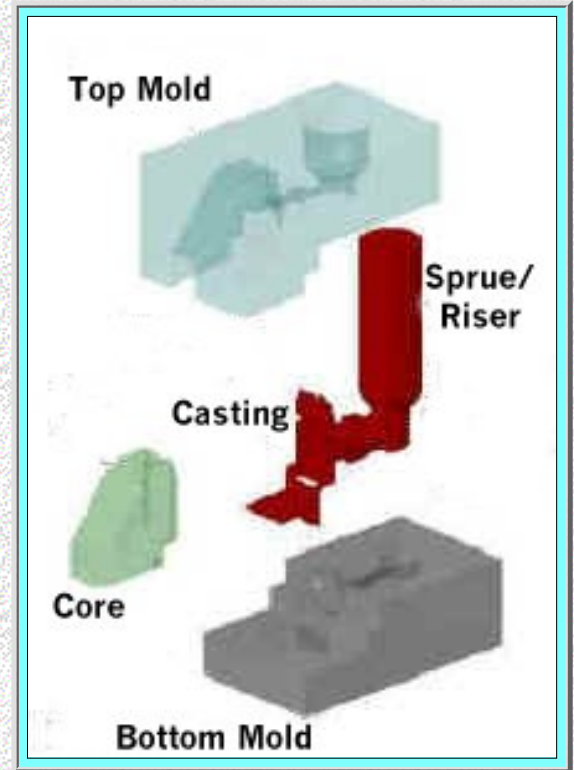

The optimized and verified mold design was used for producing long life steel dies for full production, precision diecasting.



[Back](#) [Next](#)

26



[Return to AFS](#)
[Home Page](#)

Copyright 2002 by the American Foundry Society. All rights reserved.
Address comments to: jss@afsinc.org
Last Modified: September, 2002 by STG



[Page 1](#)

In cooperation with
[prototype casting, Inc](#)





A Design Study in Rapid Prototyping for Castings

Lessons Learned

Prototype Casting and InFocus engineers worked closely together on engineering this prototype casting.



The successful production of the prototype illustrates that --

- Magnesium was the material of choice for weight and stiffness, understanding that magnesium casting requires careful process control
- Careful casting design of the thin walls and flow patterns is necessary to produce smooth metal flow and minimize transitions, which produced castings without microcracking or cold tears.
- Optimized engineering used a single core mold design in this complex piece, reducing die complexity and cost.



[Back](#) [Next](#)

27



[Return to AFS Home Page](#)

Copyright 2002 by the American Foundry Society. All rights reserved.
Address comments to: jss@afsinc.org
Last Modified: September, 2002 by STG



[Page 1](#)

In cooperation with
[prototype casting, Inc](#)





Summary

Interface Frame for LCD Projector

- The interface frame for the InFocus LP130 projector was prototyped in magnesium in a cost-effective, fast-cycle process by Prototype Casting.
- The development cycle time was three weeks from first CAD file to the final design machined casting



For further information on the application of rapid prototyping for castings, contact -- Brett Peak at Prototype Casting, Inc.
 Phone-- 303-574-0060, E-mail -- brett@protcast.com
 Web Site = <http://www.protcast.com/>

Acknowledgment --

The metalcasting design studies are a joint effort of the American Foundry Society and the Steel Founders' Society of America. Project funding was provided by the American Metalcasting Consortium Project, which is sponsored by the Defense Supply Center Philadelphia and the Defense Logistics Agency, Ft. Belvoir, VA.



[Back One](#)

The End



[Return to AFS Home Page](#)

Copyright 2002 by the American Foundry Society, All rights reserved.
 Address comments to: jss@afsinc.org
 Last Modified: September, 2002 by STG



[Page 1](#)

In cooperation with
[prototype casting, Inc](#)

